



MIAMI-DADE COUNTY
PRODUCT CONTROL SECTION

11805 SW 26 Street, Room 208
Miami, Florida 33175-2474
T (786) 315-2590 F (786) 315-2599

DEPARTMENT OF REGULATORY AND ECONOMIC RESOURCES (RER)
BOARD AND CODE ADMINISTRATION DIVISION

www.miamidade.gov/economy

NOTICE OF ACCEPTANCE (NOA)

Designer Products LLC dba Cambek Designer Doors
702 Troy Street
River Falls, WI 54022

SCOPE: This NOA is being issued under the applicable rules and regulations governing the use of construction materials. The documentation submitted has been reviewed and accepted by Miami-Dade County RER-Product Control Section to be used in Miami Dade County and other areas where allowed by the Authority Having Jurisdiction (AHJ).

This NOA shall not be valid after the expiration date stated below. The Miami-Dade County Product Control Section (In Miami Dade County) and/or the AHJ (in areas other than Miami Dade County) reserve the right to have this product or material tested for quality assurance purposes. If this product or material fails to perform in the accepted manner, the manufacturer will incur the expense of such testing and the AHJ may immediately revoke, modify, or suspend the use of such product or material within their jurisdiction. RER reserves the right to revoke this acceptance, if it is determined by Miami-Dade County Product Control Section that this product or material fails to meet the requirements of the applicable building code.

This product is approved as described herein, and has been designed to comply with the Florida Building Code, including the High Velocity Hurricane Zone.

DESCRIPTION: Insulated and Glazed Wood Sectional Garage Door up to 10'-6" Wide

APPROVAL DOCUMENT: Drawing No. 1140, titled "10'-6" Wide Glazed Hurricane Impact Wood Garage Doors", sheets 1 through 5 of 5, prepared by W. W. Schaefer Engineering & Consulting, P.A., dated 07/24/2002, with last revision F1 dated 11/13/2018, signed and sealed by Warren W. Schaefer, P.E., bearing the Miami-Dade County Product Control revision stamp with the Notice of Acceptance number and expiration date by the Miami-Dade County Product Control Section.

MISSILE IMPACT RATING: Large and Small Missile Impact Resistant

LABELING: A permanent label with the manufacturer's name or logo, manufacturing address, model/series number, the positive and negative design pressure rating, indicate impact rated if applicable, installation instruction drawing reference number, approval number (NOA), the applicable test standards, and the statement reading 'Miami-Dade County Product Control Approved' is to be located on the door's side track, bottom angle, or inner surface of a panel.

RENEWAL of this NOA shall be considered after a renewal application has been filed and there has been no change in the applicable building code negatively affecting the performance of this product.

TERMINATION of this NOA will occur after the expiration date or if there has been a revision or change in the materials, use, and/or manufacture of the product or process. Misuse of this NOA as an endorsement of any product, for sales, advertising or any other purposes shall automatically terminate this NOA. Failure to comply with any section of this NOA shall be cause for termination and removal of NOA.

ADVERTISEMENT: The NOA number preceded by the words Miami-Dade County, Florida, and followed by the expiration date may be displayed in advertising literature. If any portion of the NOA is displayed, then it shall be done in its entirety.

INSPECTION: A copy of this entire NOA shall be provided to the user by the manufacturer or its distributors and shall be available for inspection at the job site at the request of the Building Official. An original signed and sealed company letter from Designer Doors, Inc., is required, proving that the 10'-6" wide Glazed Wood Sectional Garage Door was purchased from them in order for this NOA to be valid on any job.

This NOA revises NOA # 17-0712.11 and consists of this page 1 and evidence pages E-1, E-2 and E-3, as well as approval document mentioned above.

The submitted documentation was reviewed by **Carlos M. Utrera, P.E.**



Signature
10/10/2019

NOA No. 18-1128.05
Expiration Date: October 10, 2022
Approval Date: January 10, 2019
Page 1

NOTICE OF ACCEPTANCE: EVIDENCE SUBMITTED

1. Evidence Submitted Under Previous NOAs

A. DRAWINGS “Submitted under NOA # 16-1216.06”

1. Drawing No. 1140, titled “10’-6” Wide Glazed Hurricane Impact Wood Garage Doors”, sheets 1 through 5 of 5, prepared by W. W. Schaefer Engineering & Consulting, P.A., dated 07/24/2002, with last revision E1 dated 12/12/2016, signed and sealed by Warren W. Schaefer, P.E.

B. TESTS “Submitted under NOA # 10-1119.01”

1. Test reports on 1) Large Missile Impact Test per FBC, TAS 201-94
2) Cyclic Wind Pressure Loading per FBC, TAS 203-94
along with marked-up drawings and installation diagram on a Series/Model H2/4 Section, glazed garage door, prepared by Architectural Testing, Inc., Test Report No. 94833.01-201-18, dated 01/13/2010, signed and sealed by Joseph A. Reed, P.E.
2. Addendum letter to Test Reports No. 87472.01-201-18 and 87473.01-201-18 on Forced Entry Test per FBC, FBC 2411 3.2.1, TAS 202-94, prepared by Architectural Testing, Inc., dated 08/18/2009, signed and sealed by Joseph A. Reed, P.E.

“Submitted under NOA # 02-0807.01”

3. Test reports on 1) Uniform Static Air Pressure Test Loading per SFBC, PA 202-94
2) Cyclic Wind Pressure Loading per SFBC, PA 203-94
3) Large Missile Impact Test per SFBC, PA 201-94
along with marked-up drawings and installation diagram of a glazed wood clad garage door, both prepared by Architectural Testing, Inc., Test Report No. 02-33027.01 and No. 02-33946.01, dated 10/10/2001 and 03/07/2002, signed and sealed by Allen Reeves, P.E. and Steven Urich, P.E. respectively.

C. CALCULATIONS “Submitted under NOA # 16-1216.06”

1. Anchor verification calculations prepared by W.W. Schaefer Engineering & Consulting, P.A., dated 11/27/2001 and revised on 12/12/2016, signed and sealed by Warren W. Schaefer, P.E.

“Submitted under NOA # 10-1119.01”

2. Anchor verification calculations prepared by W.W. Schaefer Engineering & Consulting, P.A., dated 11/27/2001 and revised 11/15/2010, signed and sealed by Warren W. Schaefer, P.E.

D. QUALITY ASSURANCE

1. Miami-Dade Department of Regulatory and Economic Resources (RER)

10/03/2019

Carlos M. Utrera, P.E.
Product Control Examiner
NOA No. 18-1128.05
Expiration Date: October 10, 2022
Approval Date: January 10, 2019

NOTICE OF ACCEPTANCE: EVIDENCE SUBMITTED

E. MATERIAL CERTIFICATIONS

1. Notice of Acceptance No. **16-1117.01**, issued to **Kuraray America, Inc.** for their “**Trosifol® Ultraclear, Clear and Color PVB Glass Interlayers**” approved on 01/19/2017, expiring on 04/08/2019.
2. Notice of Acceptance No. **15-1201.11** issued to **Eastman Chemical Company (MA)** for their “**Saflex Clear and Color Glass Interlayers**” approved on 03/17/2016, expiring on 05/21/2021.

F. STATEMENTS “Submitted under NOA # 16-1216.06”

1. Statement letter of code conformance to the 5th edition (2014) FBC issued by W.W. Schaefer Engineering & Consulting, P.A., dated 12/12/2016, signed and sealed by Warren W. Schaefer, P.E.
 2. Statement letter of no financial interest, issued by W.W. Schaefer Engineering & Consulting, P.A., dated 12/12/2016, signed and sealed by Warren W. Schaefer, P.E.
- “Submitted under NOA # 14-1118.08”**
3. Asset purchase agreement dated 04/25/2014.

2. Evidence submitted under NOA # 17-0712.11

A. DRAWINGS

1. None.

B. TESTS

1. None.

C. CALCULATIONS

1. None.

D. QUALITY ASSURANCE

1. Miami-Dade Department of Regulatory and Economic Resources (RER)

E. MATERIAL CERTIFICATIONS

1. None.

F. STATEMENTS

1. Statement letter of code conformance to the 6th Edition (2017) FBC issued by W.W. Schaefer Engineering & Consulting, P.A., dated 07/06/2017, signed and sealed by Warren W. Schaefer, P.E.



01/03/2019

Carlos M. Utrera, P.E.
Product Control Examiner
NOA No. 18-1128.05
Expiration Date: October 10, 2022
Approval Date: January 10, 2019

NOTICE OF ACCEPTANCE: EVIDENCE SUBMITTED

3. New evidence submitted

A. DRAWINGS

1. Drawing No. **1140**, titled "10'-6" Wide Glazed Hurricane Impact Wood Garage Doors", sheets 1 through 5 of 5, prepared by W. W. Schaefer Engineering & Consulting, P.A., dated 07/24/2002, with last revision F1 dated 11/13/2018, signed and sealed by Warren W. Schaefer, P.E.

B. TESTS

1. None.

C. CALCULATIONS

1. None.

D. QUALITY ASSURANCE

1. Miami-Dade Department of Regulatory and Economic Resources (RER)

E. MATERIAL CERTIFICATIONS

1. None.

F. STATEMENTS

1. Asset purchase agreement dated 11/08/2017.



Carlos M. Utrera, P.E.
Product Control Examiner
NOA No. 18-1128.05
Expiration Date: October 10, 2022
Approval Date: January 10, 2019

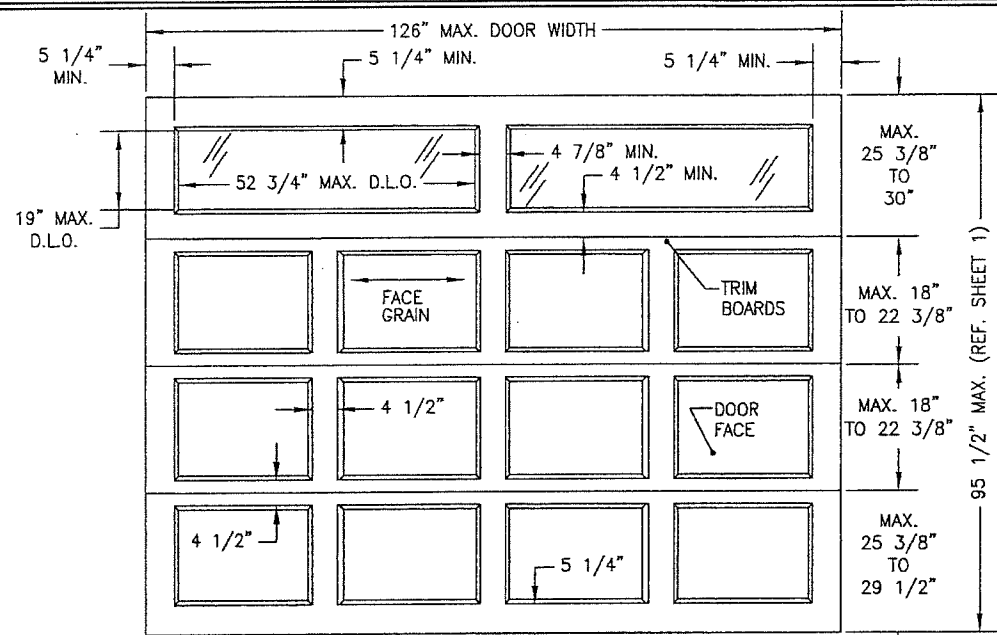

TYP. RAISED PANEL EXTERIOR ELEVATION

(2-LIGHT DOOR SHOWN; SEE BELOW FOR TYP. ELEVATION OF 3-LIGHT DOOR SECTION ALSO APPLICABLE)

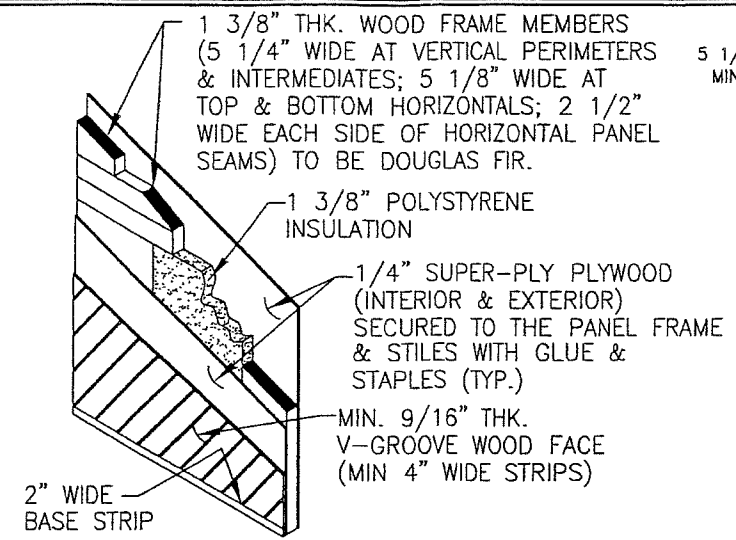

TYP. V-GROOVE PANEL
(V-GROOVE MAY RUN IN ANY DIRECTION)

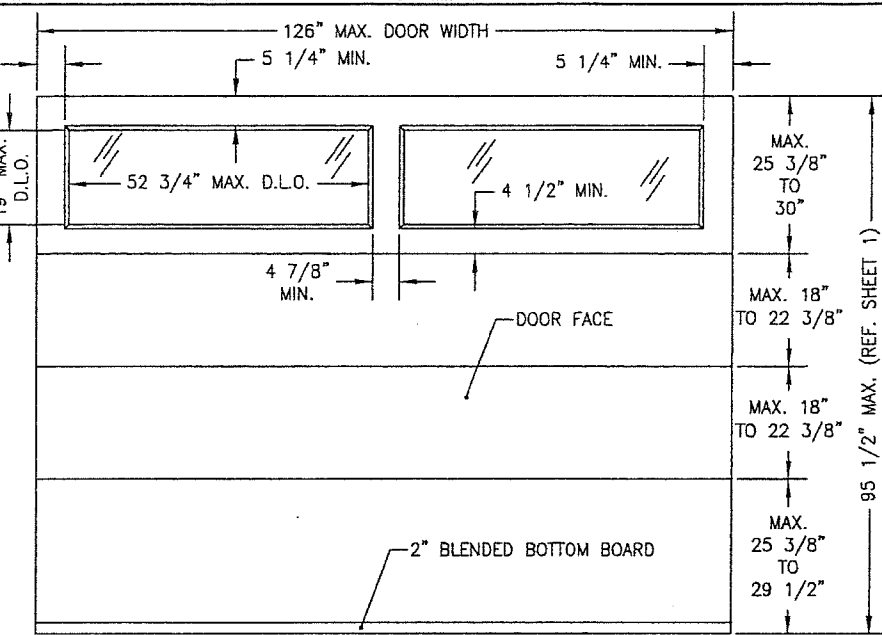

TYP. FLAT PANEL EXTERIOR ELEVATION

(2-LIGHT DOOR SHOWN; SEE BELOW FOR TYP. ELEVATION OF 3-LIGHT DOOR SECTION ALSO APPLICABLE)

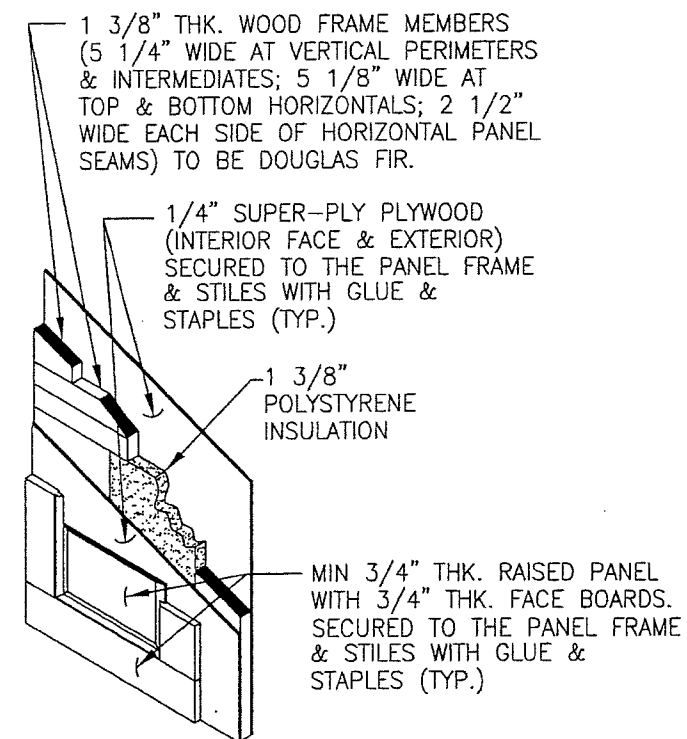

TYP. RAISED PANEL

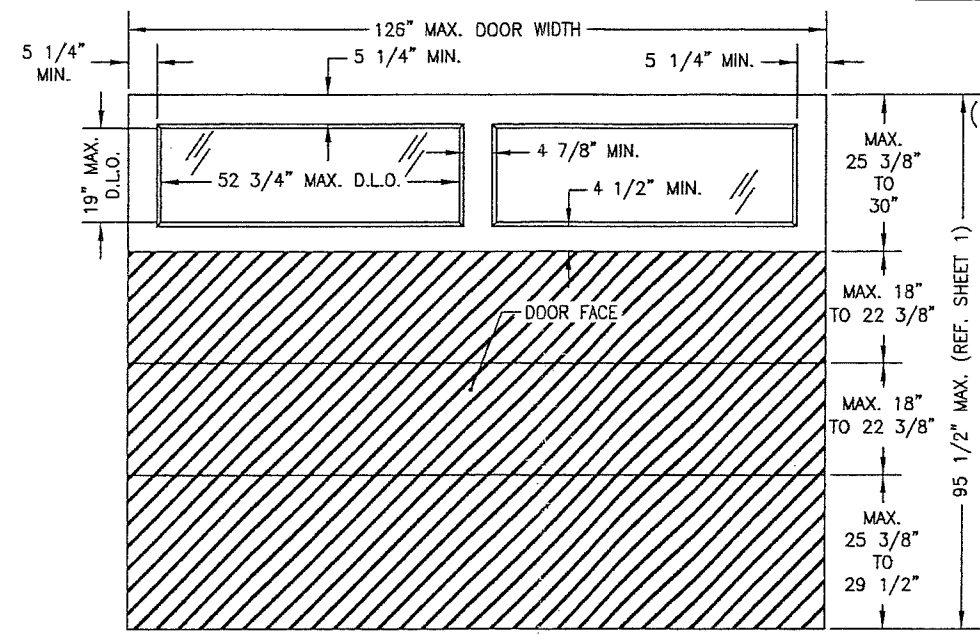

TYP. V-GROOVE PANEL EXTERIOR ELEVATION

(V-GROOVE MAY RUN IN ANY DIRECTION)
(2-LIGHT DOOR SHOWN; SEE BELOW FOR TYP. ELEVATION OF 3-LIGHT DOOR SECTION ALSO APPLICABLE)

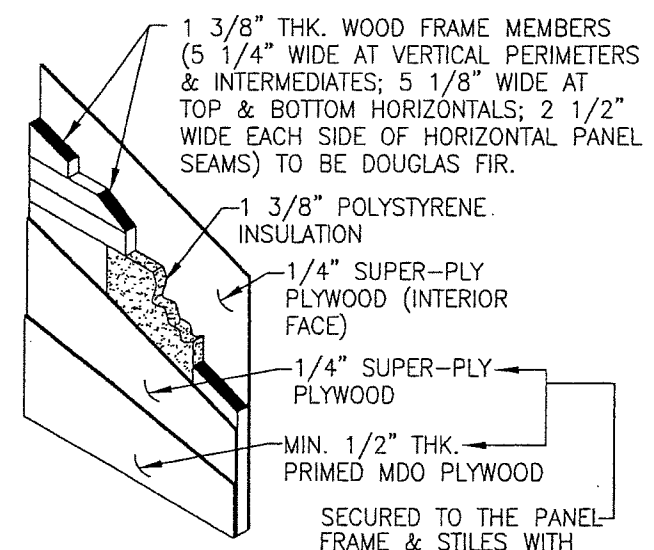

TYP. FLAT PANEL

SECURED TO THE PANEL FRAME & STILES WITH GLUE & STAPLES (TYP.)

NOTE: GLAZED DOOR SECTION MAY BE LOCATED EITHER AT THE TOP OR TOP MIDDLE SECTIONAL OF THE DOOR.

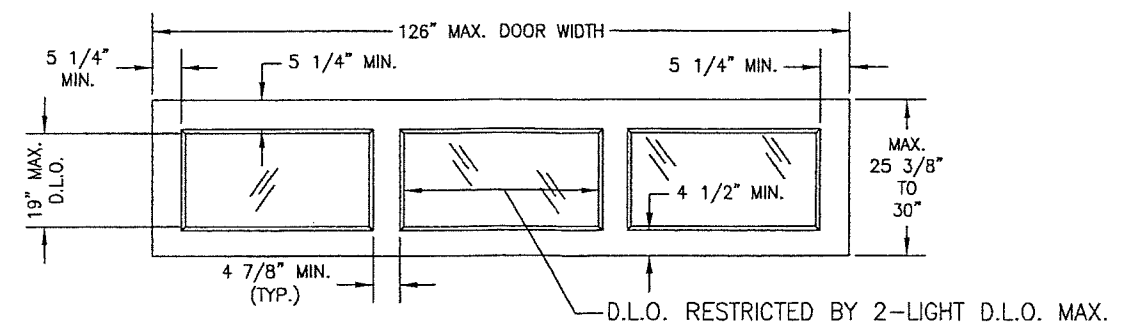

TYP. 3-LIGHT SECTION

PRODUCT REVISED
as complying with the Florida Building Code
NOA-No. **18-1128.05**
Expiration Date **10/10/2022**
By *[Signature]*
Miami-Dade Product Control

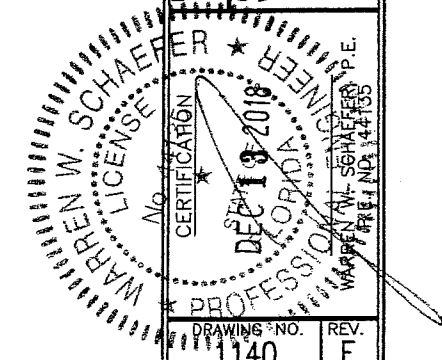

DRAWN BY: W.W.S.	CHECKED BY: W.W.S.
PLOT: 1=32	DATE: 07/24/02
NO.	REVISION DESCRIPTION
DATE	BY
DRAWING TITLE 10'-6" WIDE GLAZED HURRICANE IMPACT WOOD GARAGE DOORS	
MANUFACTURER DESIGNER PRODUCTS, LLC dba CAMBEK DESIGNER DOORS	
CONSULTANTS W. W. SCHAEFER ENGINEERING & CONSULTING, P.A. (CA 6809)	
ADDRESS 7480 150TH COURT NORTH PALM BEACH GARDENS, FL 33418 PHONE: 561-744-3424	
ADDRESS 702 TROY ST. RIVER FALLS, WI 54022 800-241-0525	
DRAWING NO.	REV.
1140	F
SHEET NO.	OF
2	5

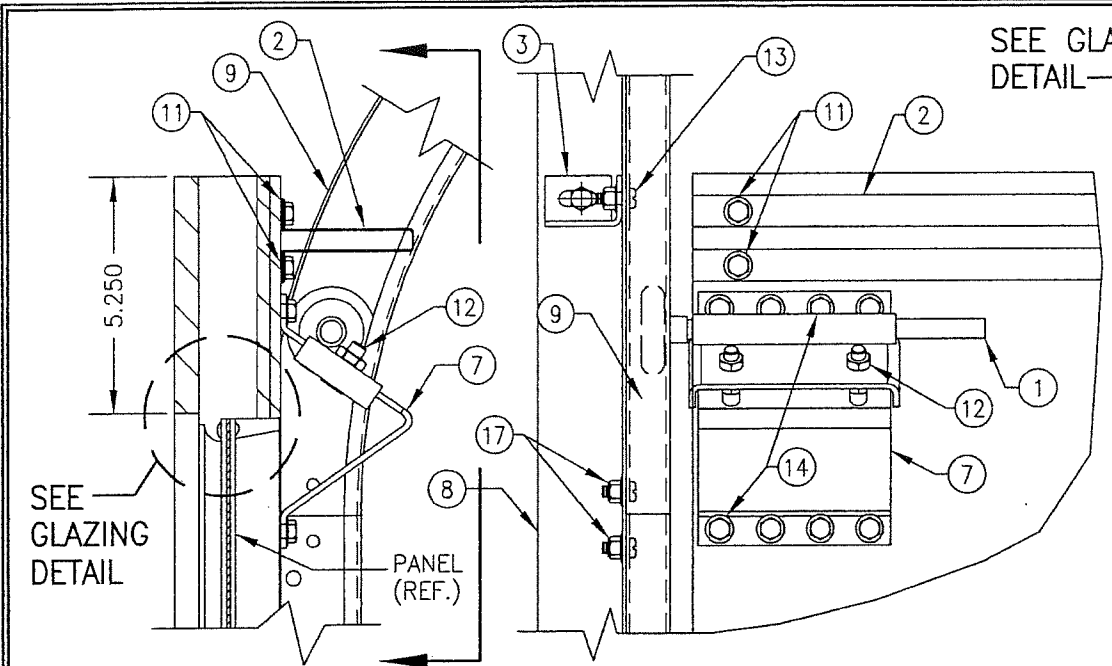

DETAIL 2

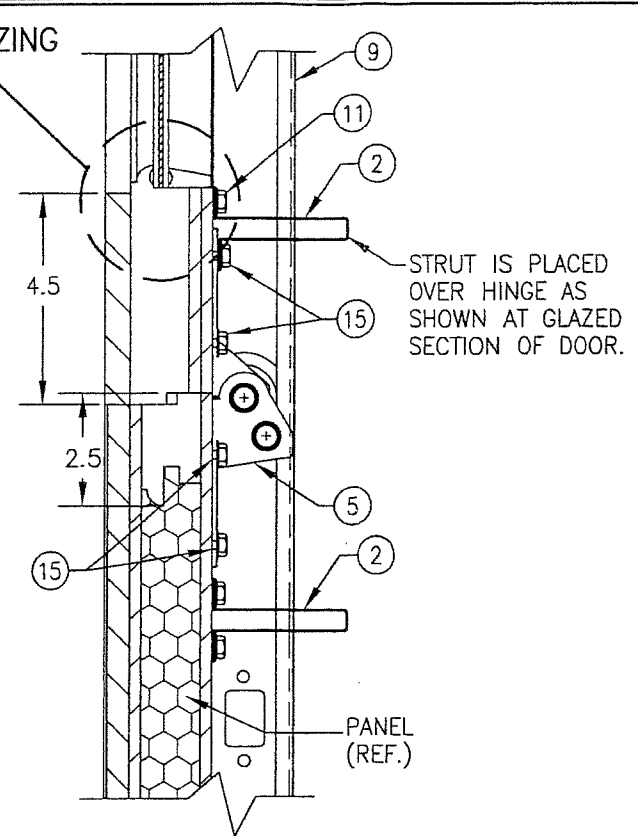

DETAIL 4

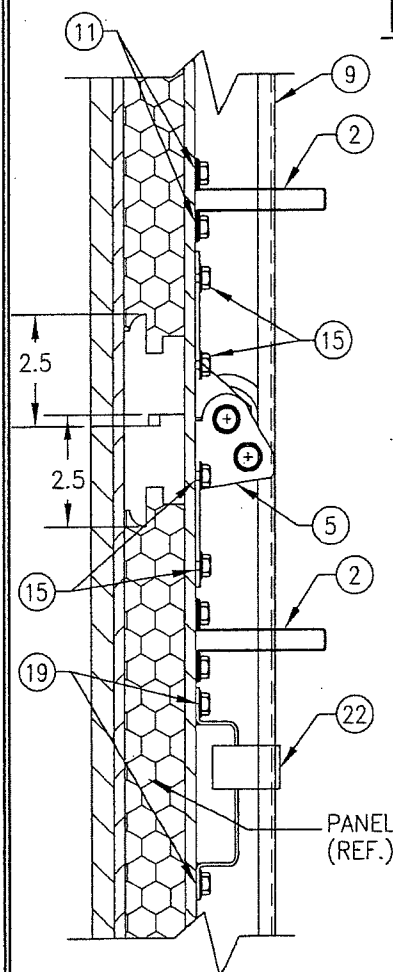

DETAIL 1

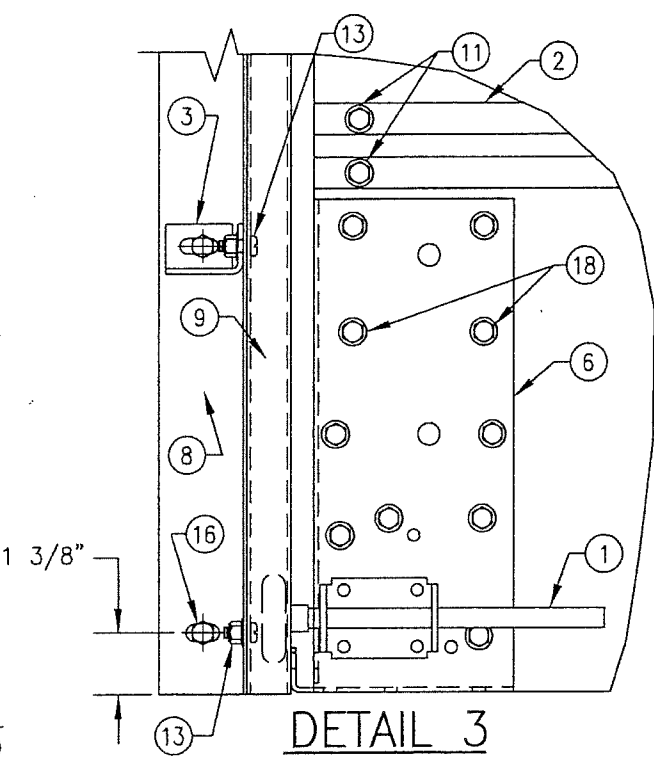

DETAIL 3

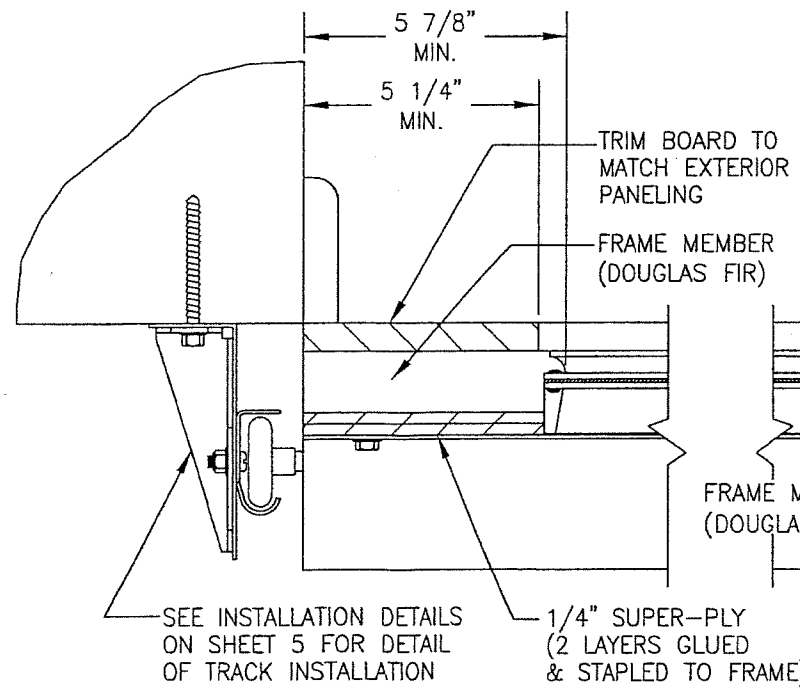

SECTION D
SCALE: 1/4 FULL

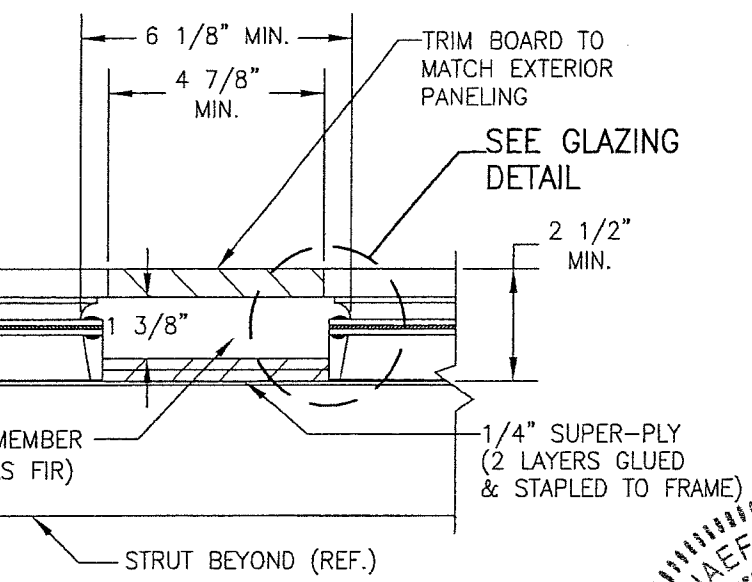

SECTION E
SCALE: 1/4 FULL

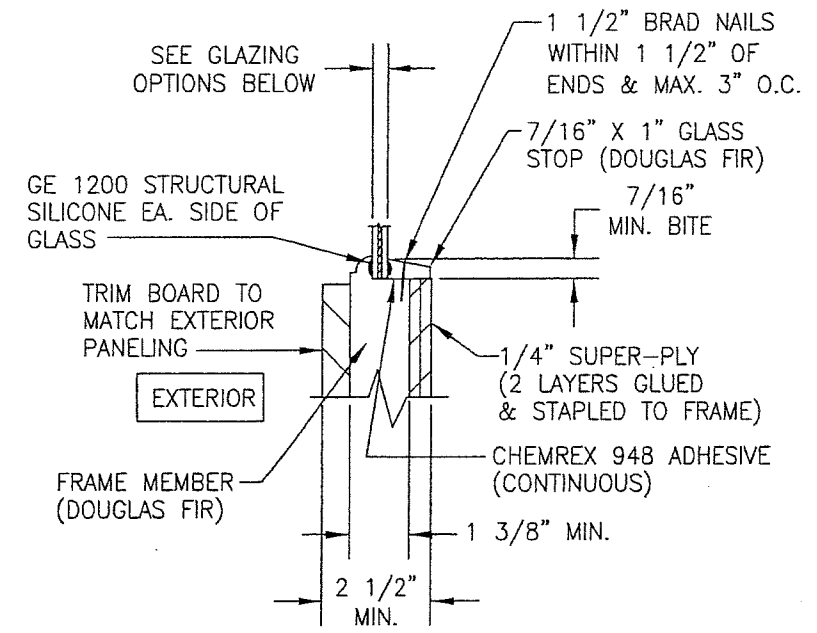

GLAZING DETAIL

GLAZING OPTIONS:
 OPTION 1: 3/8" LAMINATED GLASS (1/8" AN/0.09 EASTMAN CHEM. CO. SAFLEX/1/8" AN)
 OPTION 2: 3/8" LAMINATED GLASS (1/8" AN/0.09 KURARAY (PREVIOUSLY DUPONT) BUTACITE PVB/1/8" AN)

PRODUCT REVISED
 as complying with the Florida Building Code
 NOA-No. 18-1128.05
 Expiration Date 10/10/2022
 By *[Signature]*
 Miami-Dade Product Control

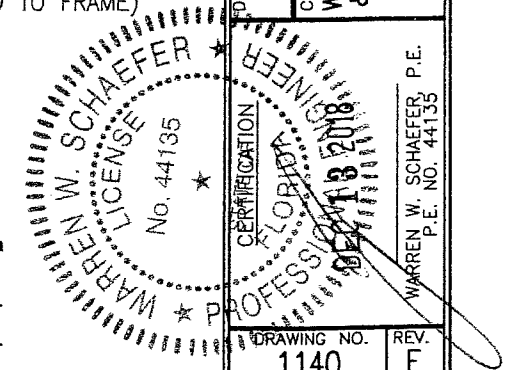

DRAWN BY: W.W.S.		CHECKED BY: W.W.S.	
PLOT: 1-4		DATE: 07/24/02	
NO.	REVISION DESCRIPTION	DATE	BY
DRAWING TITLE 10'-6" WIDE GLAZED HURRICANE IMPACT WOOD GARAGE DOORS			
CONSULTANTS W. W. SCHAEFER ENGINEERING & CONSULTING, P.A. (CA 6809)		MANUFACTURER DESIGNER PRODUCTS, LLC dba CAMBEK DESIGNER DOORS	
7480 150TH COURT NORTH PALM BEACH GARDENS, FL 33418 PHONE: 561-744-3424		702 TROY ST. RIVER FALLS, WI 54022 800-241-0525	
DRAWING NO. 1140	REV. F	SHEET NO. 3 OF 5	

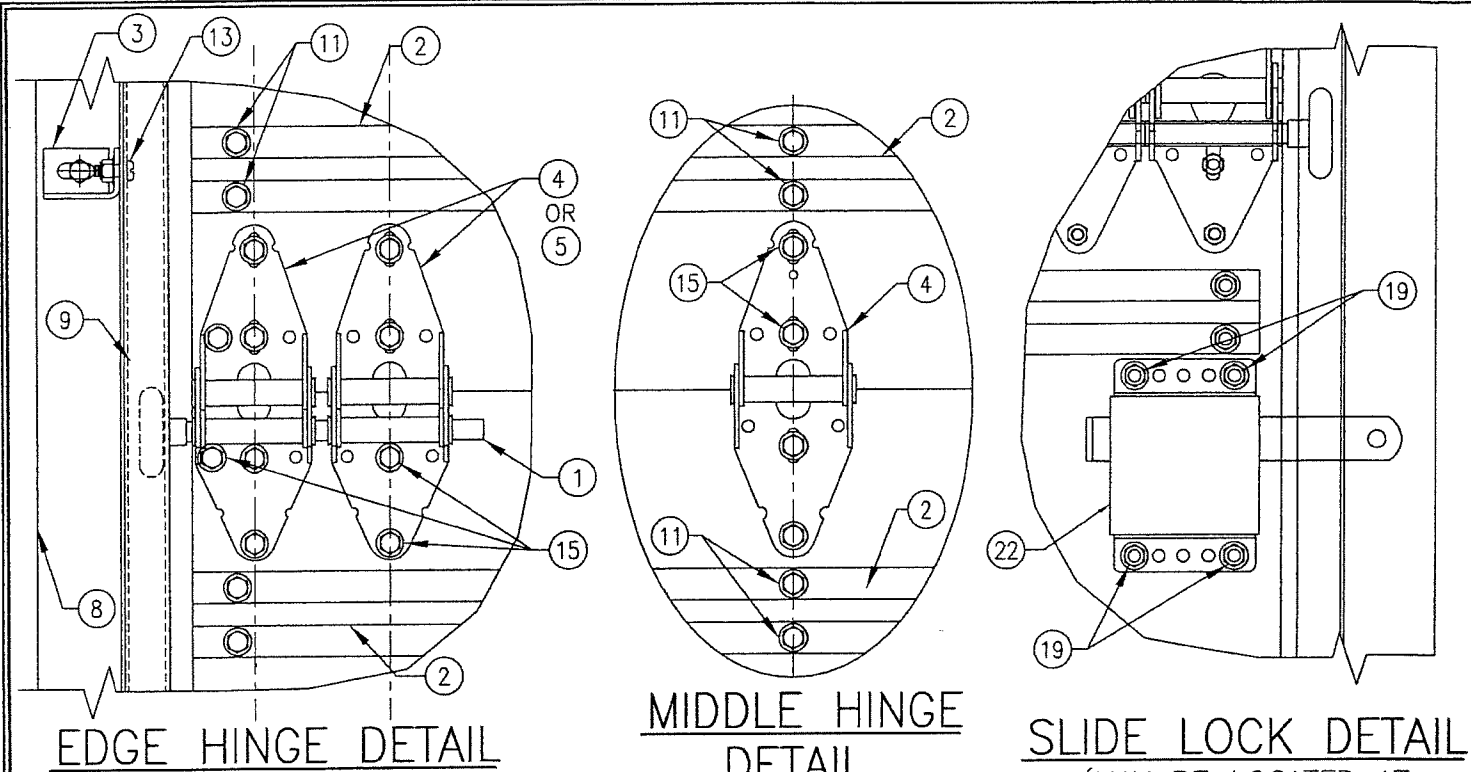

EDGE HINGE DETAIL

MIDDLE HINGE DETAIL

SLIDE LOCK DETAIL
(MAY BE LOCATED AT EITHER SIDE OF DOOR)

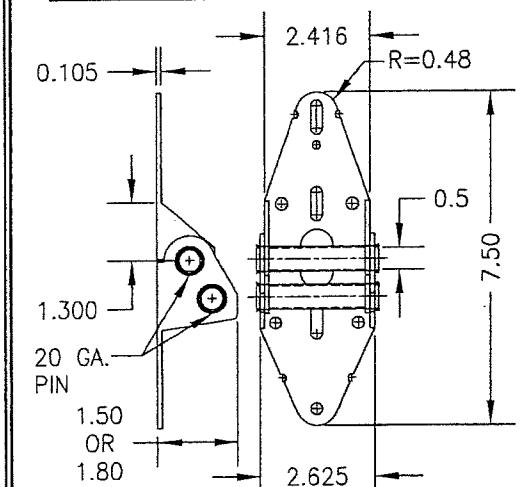

5 DOUBLE PIN HINGE

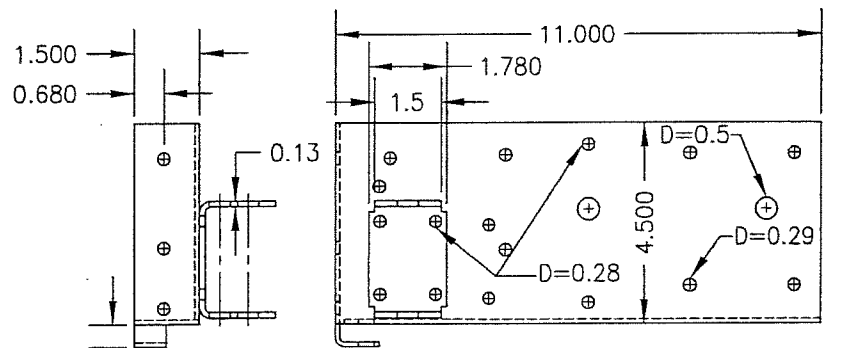

6 BOTTOM CABLE BRACKET

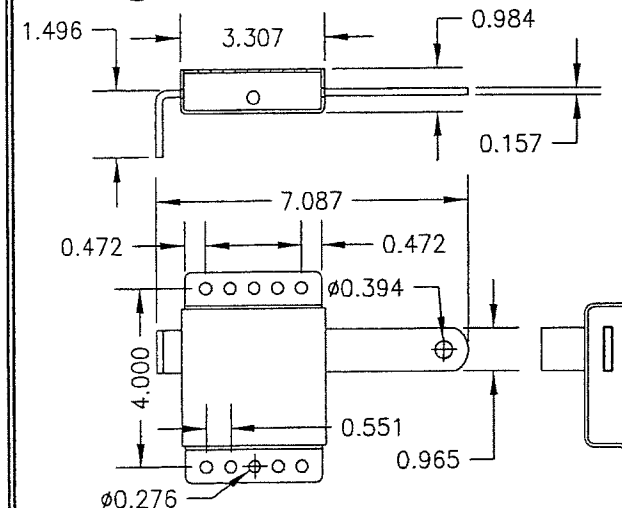

22 SLIDE LOCK

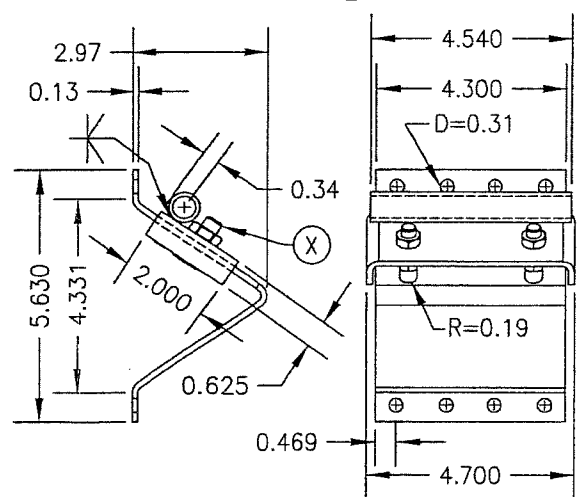

7 ADJUSTABLE TOP BRACKET

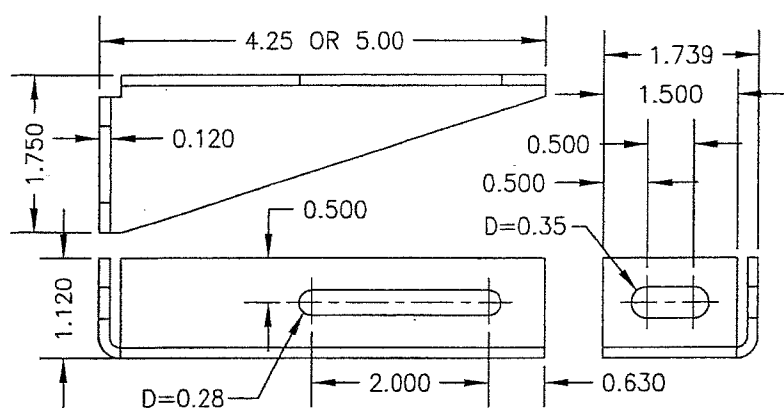

3 HURRICANE BRACKET

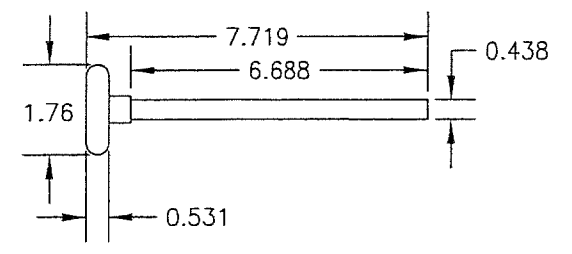

1 NYLON ROLLER WITH AISI STEEL ROD

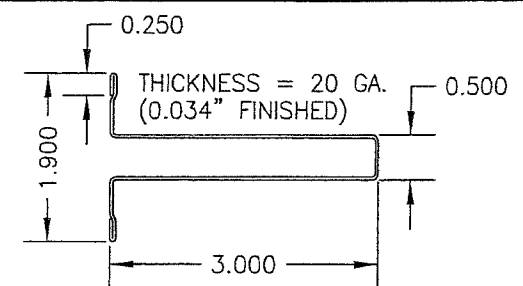

2 3" REINFORCING STRUT

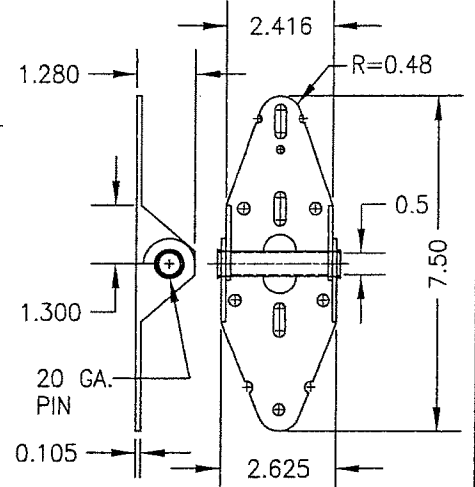

4 SINGLE PIN HINGE

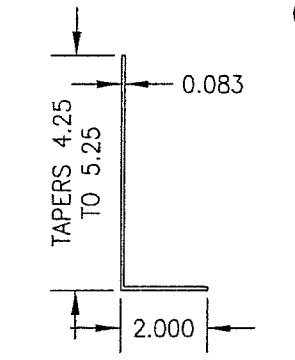

8 TRACK ANGLE

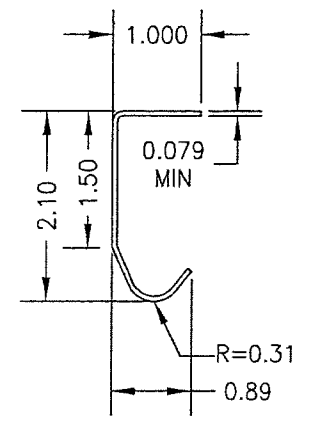

9 TRACK

PRODUCT REVISED
as complying with the Florida Building Code
NOA-No. **18-1128.05**
Expiration Date **10/10/2022**
By *[Signature]*
Miami-Dade Product Control

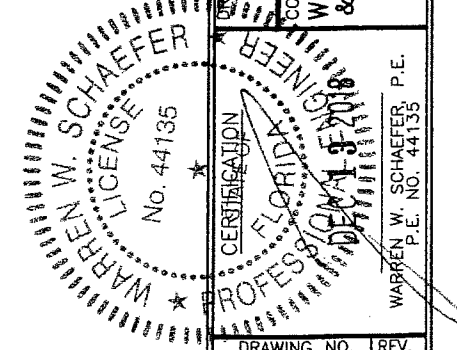

DRAWN BY: W.W.S.	CHECKED BY: W.W.S.
PLOT: 1-4	DATE: 07/24/02
NO.	REVISION DESCRIPTION
DATE	BY
DRAWING TITLE 10'-6" WIDE GLAZED HURRICANE IMPACT WOOD GARAGE DOORS	
MANUFACTURER DESIGNER PRODUCTS, LLC dba CAMBEK DESIGNER DOORS	
7480 150TH COURT NORTH PALM BEACH GARDENS, FL 33418 PHONE: 561-744-3424	
CONSULTANTS W. SCHAEFER ENGINEERING & CONSULTING, P.A. (CA 6809)	
702 TROY ST. RIVER FALLS, WI 54022 800-241-0525	
DRAWING NO.	REV.
1140	F
SHEET NO.	OF
4	5

MIN. (4) 2X STUDS (SYP WITH S.G.=0.55 MIN.) REQUIRED BY OTHERS

5/16" LAG BOLT WITH MIN. 2 1/2" FRAMING EMBED TO PENETRATE EITHER OF THE FRAMING STUDS (PREDRILL 3/16" DIAL HOLE IN FRAMING)

OPTIONAL TRIM PIECE

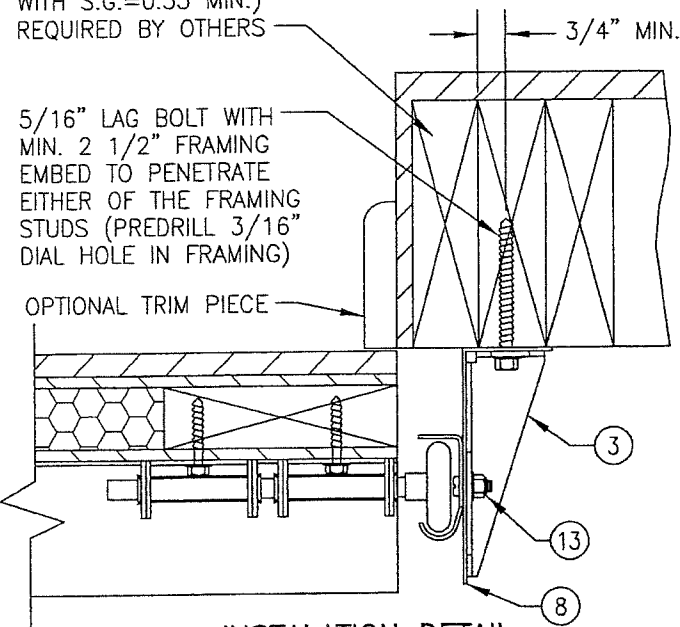

**INSTALLATION DETAIL
DIRECT TO WOOD FRAMING**

3/8" DIA. POWERS POWER-STUD SD1, POWERS POWER-STUD SD2, POWERS WEDGE BOLT SCREW ANCHOR, HILTI HUS-H SCREW ANCHOR OR HILTI KWIK-BOLT 3 EXPANSION ANCHOR (MIN. EMBED INTO SUBSTRATE = 3")

OPTIONAL TRIM PIECE

NOTE: CONCRETE MUST BE MIN 2000 PSI

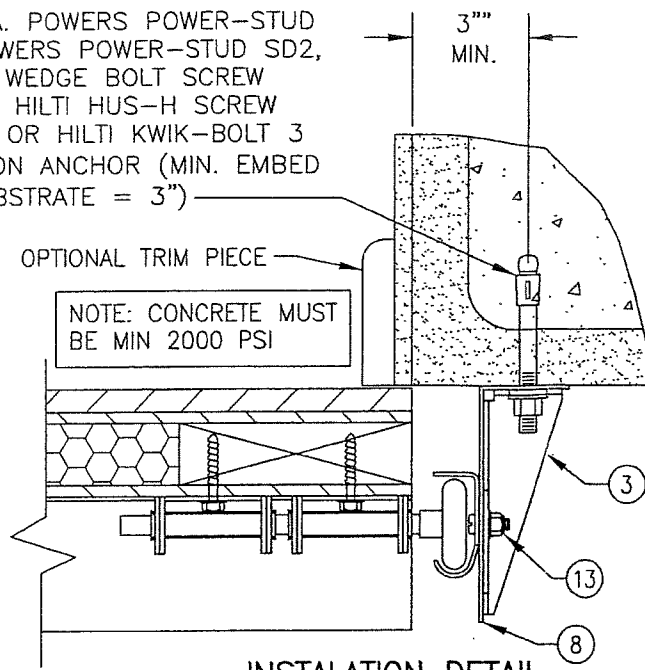

**INSTALLATION DETAIL
DIRECT TO FILLED BLOCK
OR SOLID CONCRETE**

MIN. (4) 2X STUDS (SYP WITH S.G.=0.55 MIN.) REQUIRED BY OTHERS

5/16" LAG BOLT WITH MIN. 2 1/2" FRAMING EMBED TO PENETRATE EITHER OF THE FRAMING STUDS (PREDRILL 3/16" DIAL HOLE IN FRAMING)

MIN. 2X6 NO. 2 SOUTHERN PINE P.T.

OPTIONAL TRIM PIECE

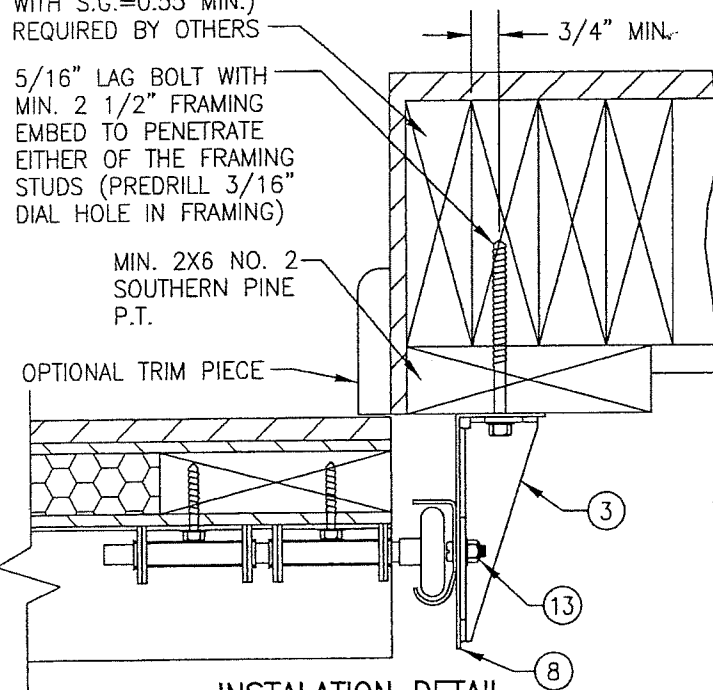

**INSTALLATION DETAIL
SHIMMED TO WOOD FRAMING**

3/8" DIA. POWERS POWER-STUD SD1, POWERS POWER-STUD SD2, POWERS WEDGE BOLT SCREW ANCHOR, HILTI HUS-H SCREW ANCHOR OR HILTI KWIK-BOLT 3 EXPANSION ANCHOR (MIN. EMBED INTO SUBSTRATE = 3")

MIN. 2X6 NO. 2 SOUTHERN PINE P.T.

OPTIONAL TRIM PIECE

NOTE: CONCRETE MUST BE MIN 2000 PSI

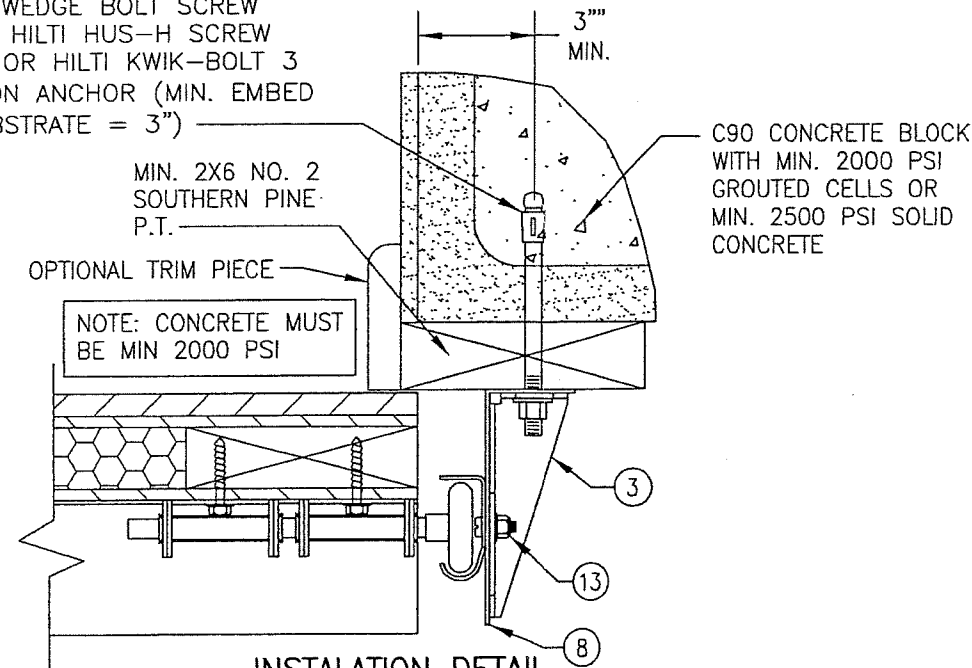

**INSTALLATION DETAIL
SHIMMED TO FILLED BLOCK
OR SOLID CONCRETE**

ITEM #	PART	ITEM DESCRIPTION	MANUFACTURER/NOTES
PARTS & HARDWARE			
1	1030-0269	ROLLER	NYLON W/AISI 1045 STL. ROD
2	1030-0213	3" REINFORCING STRUT (2 PER PANEL)	GALV. 80 KSI STEEL
3	1030-0267 1030-0268	HURRICANE BRACKET	GALV. 36 KSI STEEL
4	1030-0123	SINGLE ROLLER HINGE	GALV. 36 KSI STEEL
5	1030-0124 1030-0125	DOUBLE ROLLER HINGE	GALV. 36 KSI STEEL
6	1030-0084	BOTTOM CABLE BRACKET	GALV. 36 KSI STEEL
7	1030-0237	ADJUSTABLE TOP BRACKET	GALV. 36 KSI STEEL
8	1030-0065	TRACK ANGLE (TAPERED)	GALV. 33 KSI STEEL
9	1030-0227	VERTICAL TRACK (HORIZ. TRACK SIMILAR)	GALV. 33 KSI STEEL
10	1030-0063	HORIZONTAL REINFORCEMENT ANGLE	GALV. 33 KSI STEEL
MISCELLANEOUS FASTENERS			
11	-	1/4 X 1 1/2 HEX WASHER HEAD LAG SCREW	ALIGNED WITH HINGES CENTERLINES PER ELEVATION
12	-	3/8-16 BOLT	2 AT EACH TOP BRACKET
13	-	1/4-20 X 5/8 RIB NECK TRACK BOLT	1 PER HURRICANE BRACKET TO TRACK
14	-	1/4 X 1 1/2 HEX WASHER HEAD LAG SCREW	8 PER TOP BRACKET
15	-	1/4 X 1 1/2 HEX WASHER HEAD LAG SCREW	4 PER HINGE (6 PER EDGE HINGE)
16	-	TRACK ANCHOR AT TOP & BOTTOM OF TRACK ANGLE	PER INSTALLATION DETAIL W/D BRACKET
17	-	1/4-20 X 5/8 RIB NECK TRACK BOLT	4 AT TRACK SEAM (TRACK TO ANGLE)
18	-	1/4 X 1 1/2 HEX WASHER HEAD LAG SCREW	10 PER BOTTOM CABLE BRACKET
19	-	1/4 X 1 1/2 HEX WASHER HEAD LAG SCREW	4 PER SLIDE LOCK
LOCKING HARDWARE			
22	1030-0199	SLIDE LOCK	STEEL 1018 ZINC PLATED

PANEL NOTES:

- HORIZONTAL & VERTICAL FRAME MEMBERS ARE EDGE COPED, BUTTED TOGETHER & GLUED WITH "GORILLA GLUE." IN ADDITION, THE VERTICAL MEMBERS ARE SCREWED TO THE HORIZONTAL WITH 2 NO. 8 X 2" SCREWS ANGLED FROM THE BACK FACE OF THE DOOR.
- SUPER-PLY PLYWOOD IS STAPLED TO THE FRAME WITH 18 GA. X 5/8" X 1/4" STAPLES AND GLUED WITH CHEMREX 948 URETHANE ADHESIVE.
- THE EXTERIOR PANEL/STRIPS ARE ATTACHED TO THE SUPER-PLY AND FRAME WITH 18 GA. X 1 1/2" X 1/4" STAPLES AND CHEMREX 948 URETHANE ADHESIVE.
- EXTERIOR FINISH WOOD (PANELS/STRIPS) USED IN TESTING WAS NO. 2 WESTERN RED CEDAR WITH A SPECIFIC GRAVITY OF G = 0.32. OTHER WOOD SPECIES APPLICABLE FOR USE WITH THIS PRODUCT ARE THOSE WITH A SPECIFIC GRAVITY OF 0.32 OR GREATER.
- ALL INTERIOR FRAME MEMBERS SHALL BE NO. 2 DOUGLAS FIR WITH G = 0.49.
- IT IS THE OPTION OF DESIGNER DOOR TO INCORPORATE AN INTERIOR FINISH FACE ON ANY DOOR. THIS FACE SHALL BE EQUAL TO THOSE EXTERIOR FACES APPROVED PER THE DETAILS ON THIS DRAWING AND BE SECURED TO THE DOOR IN THE SAME MANNER AS THE EXTERIOR FACE. THIS INTERIOR FACE SHALL BE AN ADDITIONAL LAYER AND SHALL NOT REPLACE ANY LAYER SHOWN IN THE DETAILS ON THIS SHEET. ALSO, ALL HARDWARE LAG SCREWS SHALL BE LENGTHENED TO MIN. 2 1/4" TO ALLOW FOR THE ADDITIONAL THICKNESS OF THE ADDED INTERIOR SKIN.

PRODUCT REVISED
as complying with the Florida
Building Code

NOA-No. **18-1128.05**

Expiration Date **10/10/2022**

By *[Signature]*
Miami-Dade Product Control

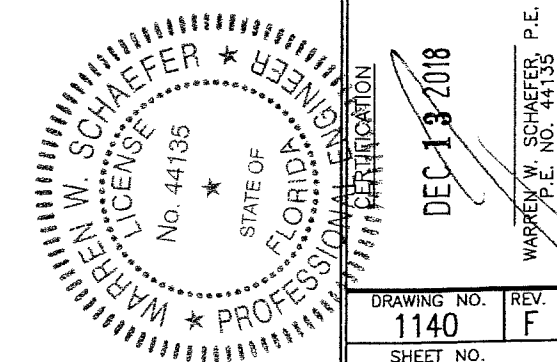

DRAWN BY: W.W.S.	CHECKED BY: W.W.S.
PLOT: 1=4	DATE: 07/24/02
DATE	
BY	
REVISION DESCRIPTION	
NO.	
DRAWING TITLE 10'-6" WIDE GLAZED HURRICANE IMPACT WOOD GARAGE DOORS	
MANUFACTURER	DESIGNER PRODUCTS, LLC dba CAMBEK DESIGNER DOORS 702 TROY ST. RIVER FALLS, WI 54022 800-241-0525
CONSULTANTS	W. W. SCHAEFER ENGINEERING & CONSULTING, P.A. (CA 6809) 7480 150TH COURT NORTH PALM BEACH GARDENS, FL 33418 PHONE: 561-744-3424
CERTIFICATION	DEC 13 2018 WARREN W. SCHAEFER, P.E. P.E. NO. 44135
DRAWING NO.	REV.
1140	F
SHEET NO.	
5	OF 5